



Trouble-shooting Manual

MODEL 222

LOAD CELL AMPLIFIER

PART NUMBER 12M03-00115-01

VOLTAGE CHECK

1. The primary voltage of 1T, leads 1 and 2 (terminals 10 and 9), should be 120V AC.
2. The secondary voltage of 1T, leads 3 to 4 and leads 5 to 6 should be 10V AC. These can be measured between circuit common, terminal 8 (leads 4 and 5), and each AC input to the bridge rectifier 1REC (leads 3 and 6). Voltage at the AC input to the bridge rectifier 1REC (leads 3 to 6) should be 20V AC.
3. +15V DC nominal between the positive end of capacitor 1C and terminal 8.
4. -15V DC nominal between the negative end of capacitor 2C and terminal 8.
5. +6V DC nominal (5.5 to 6.5 volts) between terminal 1 and terminal 8 (common).

BENCH TEST

MATERIALS REQUIRED:

- 1 - 120V AC Line Cord with spade lugs load end
- 4 - 120 Ohm Resistors matched within 1%
- 1 - 10.0K Ohm 1% Tolerance Resistor
- 1 - Single Phase 120V AC Source
- 1 - VOM (Simpson 260 or equivalent)
- 1 - Oscilloscope (Tektronix 2213 or equal)

1. Connect the 120 Ohm resistors between the following terminals: 1-2, 1-3, 2-4, 3-5.
2. Turn the Lag, Lag Break and Bridge Calibrate pots full CCW. Turn all the rest full CW.
3. Connect the 10.0K Ohm resistor between terminals 7 and 8.
4. Apply 120V AC to terminals 9 and 10. Make the following voltage checks with the VOM common lead on terminal 8 (negative) and the positive on terminal 6.

1P Position

Bridge Balance	2P Position Bridge Calibrate	Voltage DC
CW	Rotate from CCW to CW	-13 at 50% rotation
CW	CCW	- 0.2
CCW	CCW	+ 0.2
CCW	Rotate from CCW to CW	+13 at 50% rotation

5. Turn Bridge Balance and Bridge Calibrate potentiometers to full CW. Rotate 4P (Output Potentiometer) smoothly to CCW position. The output should smoothly drop from -13V to zero.
6. Move the positive lead of the VOM to terminal 7 — it should read 11V DC. Turn 6P (Meter Calibrate) steadily

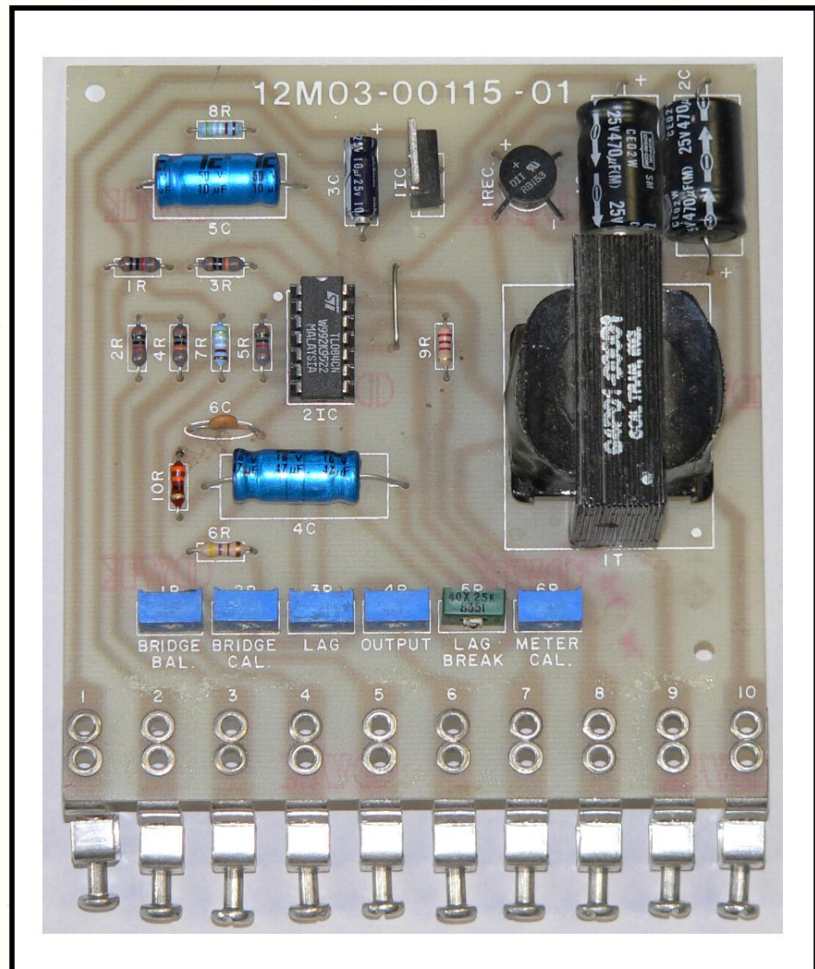

from CW to CCW position — the voltage should go to 6V DC. Turn 1P Bridge Balance full CCW. The voltage should go to -6V DC. Turn Bridge Balance and Meter Calibrate potentiometers back to full CW position.

7. Connect the positive lead of the oscilloscope to terminal 6 and the common to terminal 8. It should be -13V. Jumper the 120 Ohm resistor between terminal 1 and 2. The output should jump to +13V.
8. Remove the jumper and turn the Lag potentiometer full CW. Jumper the 120 ohm resistor between terminal 1 and 2. The output should go from -13V to +13V in approximately 1 second.
9. Remove the jumper and turn the Lag Break potentiometer to 50%. Jumper the 120 ohm resistor between terminals 1 and 2. The output should jump from -13V to approximately 0V and slowly rise from 0V to +13V.
10. Remove the jumper and turn the Lag Break potentiometer full CW. Jumper the 120 ohm resistor between terminals 1 and 2. The output should jump from -13V to +13V.

MODEL 222 LOAD CELL AMPLIFIER

PART NUMBER 12M03-00115-01
SCHEMATIC DIAGRAM 12M03-00115-01

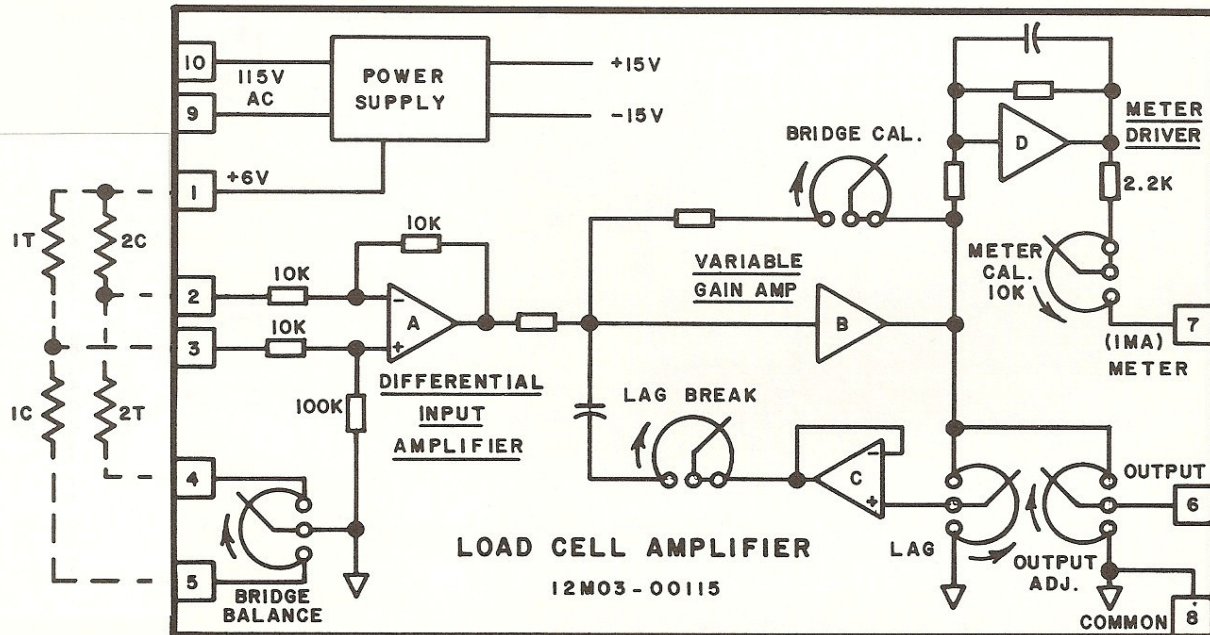

FIGURE 1. SIMPLIFIED SCHEMATIC

I. SPECIFICATIONS

SUPPLY:

- 120 volts AC + 10%
- 50/60 Hz, single phase

AMBIENT TEMPERATURE:

- 0° to 40°C (32° to 104°F)
- 50°C in cabinet

INPUT:

- From strain gage bridge with 120 ohms nominal per leg. 100mV minimum input for full output with the bridge excited with 6 volts DC

OUTPUTS:

- 0 to ± 10 volts at 5mA at terminal 6
- 0 to ± 1 mA to a 1mA meter at terminal 7

II. THEORY OF OPERATION

The REFLEX® Model 222 Load Cell Amplifier takes its input signal from a four-leg strain gage bridge and amplifies it to a nominal 10 volt full-scale level for use with control circuitry.

It consists of the following elements as shown in the Schematic Diagram (Figure 1):

1. Power Supply
2. Differential Input Amplifier
3. Variable Gain Amplifier
4. Meter Driver

1. **Power Supply** — The power supply uses a center-tapped transformer with 10 volts on each side of center together with a bridge rectifier and two 470MF capacitors to provide a nominal positive and negative unregulated 15 volts DC with respect to the transformer center-tap which is connected to circuit common.

Additionally, a regulated positive 6 volts is obtained from the positive 15 volt supply using regulator 11C with a 10MF filter capacitor.

2. **Differential Input Amplifier** — The two center terminals of each half of the strain gage bridge become the input signal to Differential Amplifier 2IC(A) which has a gain of 10 to 1. The differential mode is used to allow operation with the same power supply used to power the amplifiers and also to take advantage of the common mode rejection capabilities of the op-amp.

The lower terminal of each leg of the bridge is connected to a potentiometer that can be adjusted to compensate for resistance differences in the four elements, and also to provide a null for residual load on the bridge.

3. **Variable Gain Amplifier** — The output of the Differential Input Amplifier is fed to a Variable Gain Amplifier 2IC(B) which has a gain adjustable from approximately .05 to 10 providing an overall gain adjustable from 0.5 to 100.

This amplifier also has an adjustable active filter to minimize effects of vibration or other electrical noise output from the strain gage bridge. The time constants in this filter also allow for stability adjustment when the assembly is used for feedback in a regulating system.

Output is adjustable from zero to maximum by means of Output Potentiometer 4P.

4. **Meter Driver** — Amplifier 2IC(D) takes the output from the Variable Gain Amplifier and provides a buffered signal to an external meter. A small amount of filtering is added to minimize meter pointer bounce.

Output is adjustable by means of the Meter Calibrate Potentiometer 6P.

COMPONENT LIST — ASSEMBLY #12M03-00115-01

Symbol	Part #	Description (Acceptable Substitute)*
1T	04P01-00001	Transformer - 120V AC PRI, Two 10V AC SEC @ 220 mA (Signal - PC20-220)
1REC	05P01-00003	Rectifier Bridge - 50V, 1A (EDI-PF50)
1P	02P04-50001-00	Potentiometer, 50 Ohm, ¼W (Beckman 72XR50)
2P	02P04-10401-00	Potentiometer, 100K (Beckman 72XR100K)
3P, 6P	02P04-10301-00	Potentiometer, 10K (Beckman 72XR10K)
4P	02P04-50201-00	Potentiometer, 5K (Beckman 72XR5K)
5P	02P04-25301-00	Potentiometer, 25K (Beckman 72XR25K)
1IC	05P08-00006	+6 Volt Regulator (7806)
2IC	05P08-00002	Quad Op-Amp (TI-TL084)
1, 2C	03P01-47102-01	Capacitor, 470MF, 25V, Electrolytic
3C	03P01-10001-01	Capacitor, 10MF, 15V, Electrolytic
4C	03P02-50002	Capacitor, 50MF, 16V, Non-Polarized, Electrolytic
5C	03P02-10002	Capacitor, 10MF, 16V, Non-Polarized, Electrolytic
6C	03P06-10305-01	Capacitor, .01MF, 50V, Ceramic
1, 2, 5R	01P02-10021-01	Resistor, 10K, ½W, 1%
3, 4R	01P02-10031-01	Resistor, 100K, ½W, 1%
6R	01P01-47100-02	Resistor, 470 Ohm, ¼W, 5%
7, 8R	01P02-49921-01	Resistor, 49.9K, ½W, 1%
9R	01P01-22200-02	Resistor, 2.2K, ¼W, 5%
10R	01P01-33000-02	Resistor, 33 Ohm, ¼W, 5%

* OR EQUAL



GEMINI CONTROLS LLC
W61 N14280 TAUNTON AVE.
PO BOX 380
CEDARBURG, WI 53012
www.geminicontrols.com

PHONE: (262)-377-8585
FAX: (262)-377-4920
email:sales@geminicontrols.com

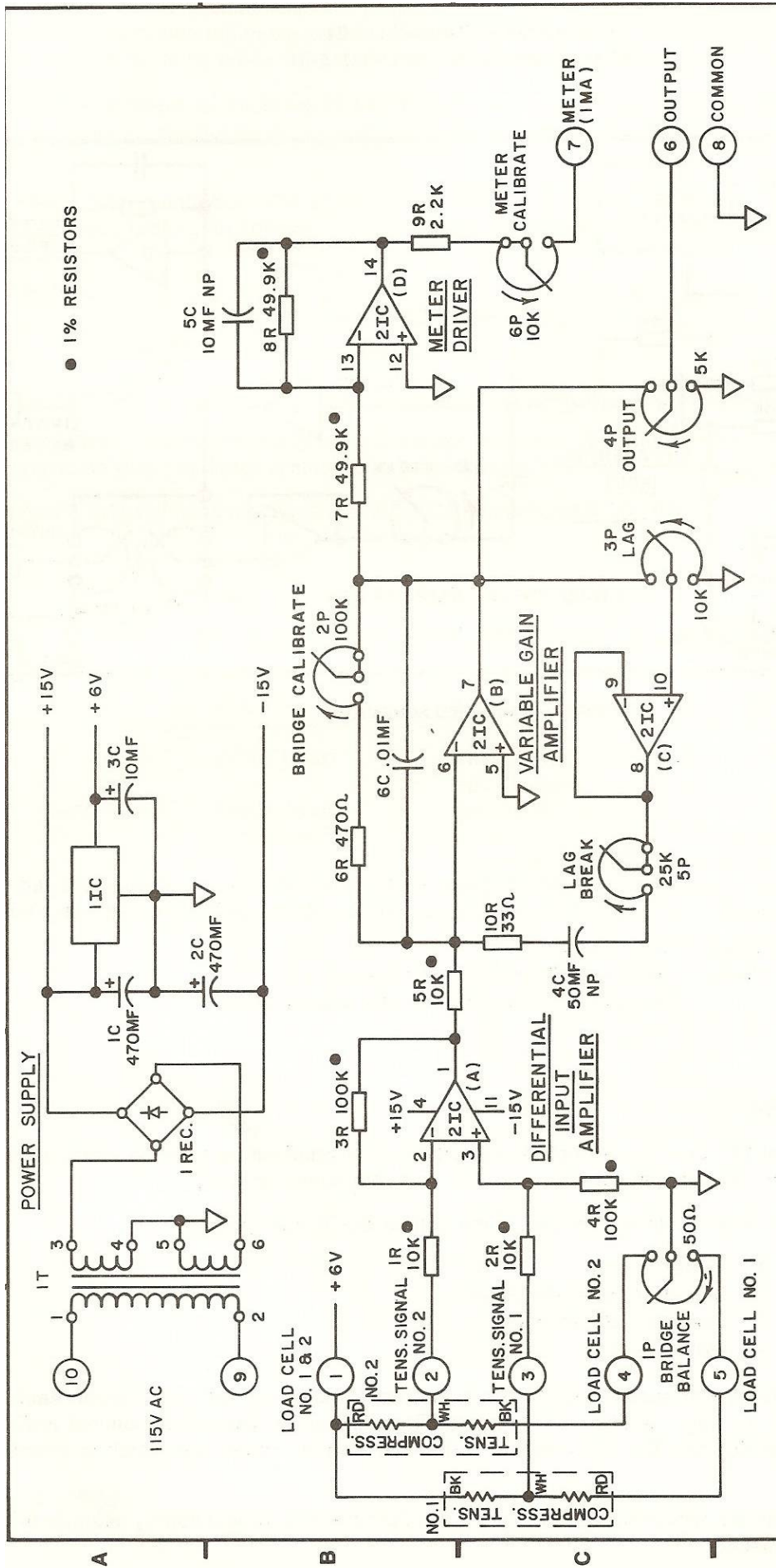

● 1% RESISTORS

DR	MY	CKD	APP'D	GEMINI CONTROLS CEDARBURG, WI
DATE	SCALE	SHEET	OF	
4-12-84				
PRODUCT	LOAD CELL AMPLIFIER		REF. FILE NO.	EX-222
CUSTOMER			JOB NO.	
TITLE	SCHEMATIC DIAGRAM		DWG. NO.	12M03-00115-01

PCB. NO. 13S01-00115-01
LAYOUT NO. 12M03-00115-01

"CONFIDENTIAL"
THIS DOCUMENT AND ALL INFORMATION HEREIN CONTAINED, INCLUDING ALL OF THE DETAILS AND CONCEPTS DISCLOSED OR SUGGESTED IS THE EXCLUSIVE PROPRIETARY PROPERTY OF REFLEX INC., AND IS DISCLOSED WITH THE UNDERSTANDING THAT IT WILL BE RETAINED IN STRICT CONFIDENCE. THAT IT WILL NOT BE DUPLICATED IN WHOLE OR IN PART, AND THAT IT WILL NOT BE USED FOR ANY OTHER PURPOSE THAN THAT FOR WHICH IT IS DISCLOSED.