



# Trouble-shooting Manual MODEL 235 VOLTAGE/ CURRENT FOLLOWER PART NUMBER 12M03-00125-01

## BENCH TEST

### TEST MATERIAL REQUIRED

- 1 - Oscilloscope
- 1 - 47K, ½ watt resistor
- 3 - Clip leads
- 1 - AC line cord with spade lugs

### 1. Initial test configuration.

- A. Set all DIP switch positions on the circuit card to "OFF."
- B. Set all pots to full CCW except "OFFSET" which should be set to its 50% position and "RATIO" which should be fully CW.
- C. Connect an oscilloscope to terminal 2 (HI) and terminal 8 (LO). Set the oscilloscope vertical input to 5 volts per division and the horizontal to 2 milli-seconds per division. Set the sync input to "LINE."
- D. Connect a 47K, ½ watt resistor from terminal 10 to terminal 5 and connect terminals 8 and 9 together.

2. Apply 120 volts AC to terminals 9 and 10 and adjust "CALIBRATION-FINE" fully CW. The output should rise smoothly from 0 to approximately 30 volts peak to peak, at which point the wave-form should begin to clip symmetrically.

3. Place DIP switch position 2 to "ON." There should be a 180 degree phase reversal on the scope. Return DIP position 2 to "OFF."

4. Place DIP switch position 1 to "ON." The scope should display a 60 Hz sine wave of about 5 volts peak-to-peak. Return DIP switch position 1 to "OFF."

5. Reduce "CALIBRATION-FINE" to a point just below clipping on the scope display. Turn "RATIO" pot CCW and back to CW. You should notice a smooth transition from the current scope display to 0 and back. Now place DIP switch position 3 to "ON." The scope display should now be ½ the previous magnitude and twice the frequency (120 Hz) and instead of a sine wave, a full wave rectified pattern should be seen. Return DIP switch position 3 to "OFF."

6. Place DIP switch position 4 to "ON." The scope display should collapse to 0 volts.

7. Turn "CALIBRATION COARSE" to full CW. Oscilloscope should display a 60 Hz sine wave of about 20 volts peak to peak. Return "CALIBRATION COARSE" to full CCW.

8. Adjust "OFFSET" to full CW and back to full CCW. The oscilloscope display should move about 4 volts DC above and below the 50% position it was set at.

9. Place DIP switch position 4 to "OFF" and remove power.

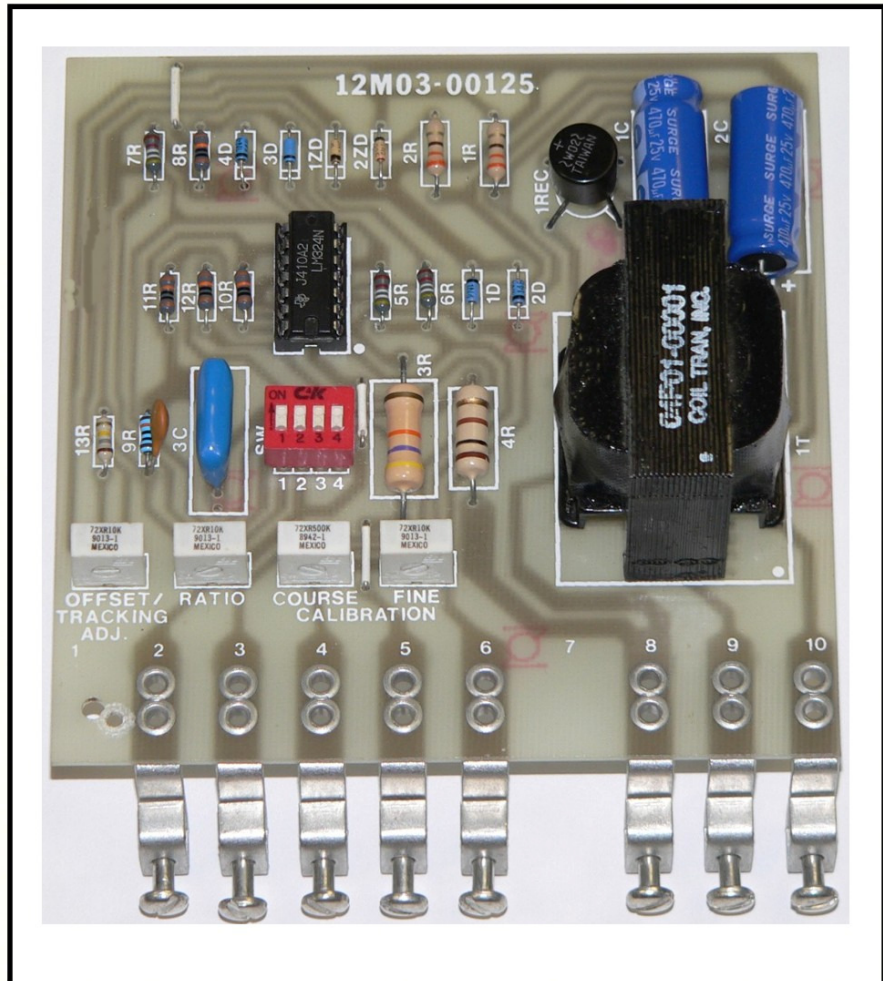

# GEMINI MODEL 235 VOLTAGE / CURRENT FOLLOWER

PART NUMBER 12M03-00125-01

SCHEMATIC DIAGRAM NUMBER 12M03-00125-01

## I. SPECIFICATIONS

### SUPPLY:

- 120 Volts AC  $\pm$  10%
- 50/60 Hz, Single Phase

### AMBIENT TEMPERATURE:

- 0° to 40°C (32° to 104°F)
- 50°C in cabinet

### INPUT:

- Current:  
Standard instrument outputs of  $\pm$  1 to 5,  $\pm$  4 to 20 or  $\pm$  10 to 50 mA AC or DC
- Voltage:  
0 to  $\pm$  50V AC or DC (Higher voltages with external scaling resistors)

### OUTPUT:

- 0 to  $\pm$  10V DC at 5 mA

### OPTIONS:

- Selected by 4 SPST DIP Switches
- 1 - Filter
- 2 - Inverted Output
- 3 - AC (precision rectifier)
- 4 - Current Input

### ADJUSTMENTS:

- COARSE } Adjusts gain of
- FINE } input amplifier
- OFFSET/TRACKING
- RATIO

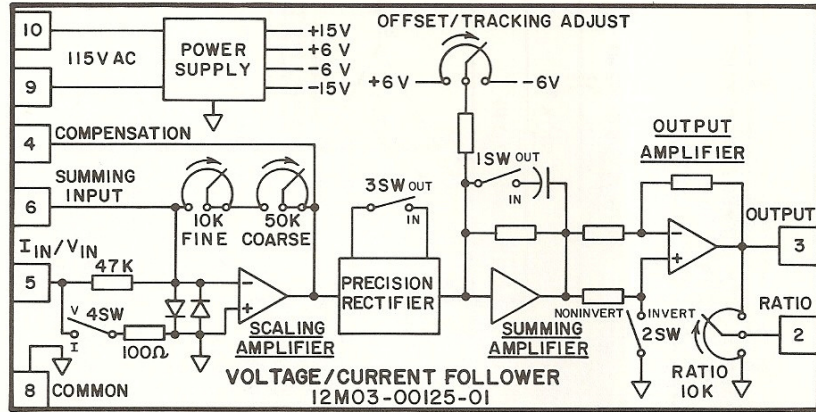

FIGURE 1 SIMPLIFIED SCHEMATIC

## II. THEORY OF OPERATION

The REFLEX Model 235 Voltage/Current Follower provides a conditioned output voltage from a Voltage or Current Signal for various types of follower applications.

It consists of the following elements as shown in the Simplified Schematic Diagram (Figure 1).

1. Power Supply
2. Scaling Amplifier
3. Precision Rectifier
4. Summing Amplifier
5. Output Amplifier

1. **Power Supply** – The power supply uses a center-tapped transformer with 10 volts on each side of center together with a bridge rectifier and two 470 MF filter capacitors to provide a nominal positive and negative unregulated 15 volts DC with respect to the transformer center tap, which is connected to circuit common.

Additionally, a positive and negative 6 volt regulated voltage is obtained from the positive and negative 15 volt supplies, using regulators 2ZD and 1ZD.

2. **Scaling Amplifier** – Op-Amp 11C(A) provides a voltage gain depending on the setting of the "FINE" and "COARSE" calibration adjustments. Switch 4SW is closed for "Current" Input.

These adjustments are normally set for 5 volts out of 11C(A) (terminal 4) for the maximum input signal. The added 2 to 1 gain of the Summing Amplifier will provide the rated 10 volts output. For current input signals the output of 11C(A) is normally set at 6.25 volts to allow for a 20% offset (4-20 mA).

3. **Precision Rectifier** – When switch 3SW is closed, op-amp 11C(B) acts as an Absolute Value Amplifier so that a positive signal is always applied to the Summing Amplifier regardless of the polarity of the input signal.
4. **Summing Amplifier** – Op-amp 11C(C) sums the signal from the Scaling Amplifier or the Precision Rectifier and the signal from the “Offset/Tracking” Potentiometer 2P. For adjustment, the input signal is normally reduced to its minimum value and this potentiometer set for the desired output.  
When 1SW is closed, 11C(C) also acts as an active single pole filter with a nominal 3.4 Hz crossover frequency. This filter is normally used with an AC input, but may also be useful in reducing undesirable noise with a DC input.
5. **Output Amplifier** – Op-amp 11C(D) has gain of unity. When switch 2SW is closed the signal is inverted. A “Ratio” Potentiometer 3P on the output provides a means of adjusting the output.

#### VOLTAGE CHECK

1. The primary voltage of 1T, leads 1 and 2 (terminals 10 and 9), should be 115V AC.
2. The secondary voltage of 1T, leads 3 to 4 and leads 5 to 6, should be 10V AC. These can be measured between circuit common, terminal 8 (leads 4 and 5) and each AC input to the bridge rectifier 1REC (leads 3 and 6). Voltage at the AC input to the bridge rectifier 1REC (leads 3 to 6) should be 20V.
3. +15V DC nominal between the positive end of capacitor for 1C and terminal 8.
4. -15V DC nominal between the negative end of capacitor 2C and terminal 8.
5. +6V DC nominal (6.4 to 7.2 volts) between the cathode of 2ZD and terminal 8.
6. -6V DC nominal (6.4 to 7.2 volts) between the anode of 1ZD and terminal 8.

#### COMPONENT LIST - ASSEMBLY #12MO3-00125-01

Symbol	Part #	Description (Acceptable Substitute)*
1T	04P01-00001	Transformer-120V AC PRI, two 10V SEC @ 220mA (Signal-PC20-220)
1REC	05P01-00003	Rectifier Bridge-50V, 1A (EDI-PF50)
1-4D	05P02-00001	Diode-Signal, 50 mA, 200 PIV (1N4148)
1, 2ZD	05P03-00005	Zener Diode-6.8V, 500mW, 10% (1N5235B)
11C	05P08-00001	Quad Op-Amp (National-LM324)
1-4SW	09P01-00004	Switch-DIP, 4-SPST, (ACCO-DSS4)
1-3P	02P04-10301-00	Potentiometer-10K, ½W (Beckman-72XR10K)
4P	02P04-50401-00	Potentiometer-500K, ½W (Beckman-72XR500K)
1, 2C	03P01-47102-01	Capacitor-470MF, 25V, Electrolytic
3C	03P07-47410-00	Capacitor-0.47MF, 100V, Film
4C	03P06-47105-00	Capacitor-470PF, 50V, Ceramic
1, 2R	01P01-33101-02	Resistor-330, ½W, 5%
3R	01P01-47303-02	Resistor-47K, 2W, 5%
4R	01P01-10102-02	Resistor-100 Ohms, 1W, 5%
5-7R	01P02-49921-01	Resistor-49.9K, ½W, 1%
8-12R	01P02-10031-01	Resistor-100K, ½W, 1%
13R	01P01-18400-02	Resistor-180K, ¼W, 5%

\* OR EQUAL



**GEMINI CONTROLS LLC**  
**W61 N14280 TAUNTON AVE.**  
**PO BOX 380**  
**CEDARBURG, WI 53012**  
**www.geminicontrols.com**

**PHONE: (262)-377-8585**  
**FAX: (262)-377-4920**  
**email:sales@geminicontrols.com**

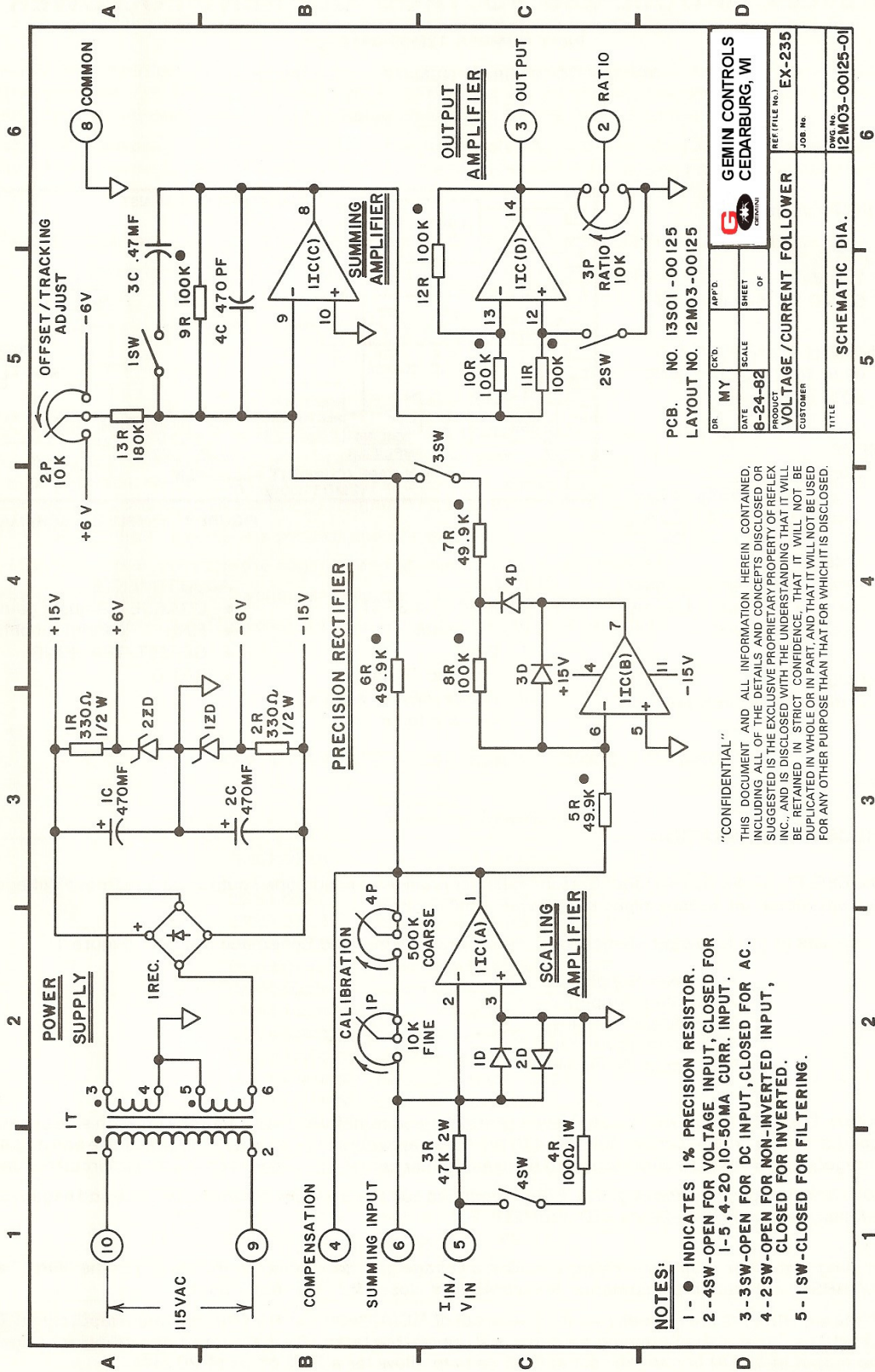

- NOTES:**
- 1 - ● INDICATES 1% PRECISION RESISTOR.
  - 2 - 4SW-OPEN FOR VOLTAGE INPUT, CLOSED FOR 1-5, 4-20, 10-50MA CURR. INPUT.
  - 3 - 3SW-OPEN FOR DC INPUT, CLOSED FOR AC.
  - 4 - 2SW-OPEN FOR NON-INVERTED INPUT, CLOSED FOR INVERTED.
  - 5 - 1SW-CLOSED FOR FILTERING.

"CONFIDENTIAL"  
 THIS DOCUMENT AND ALL INFORMATION HEREIN CONTAINED, INCLUDING ALL OF THE DETAILS AND CONCEPTS DISCLOSED OR SUGGESTED IS THE EXCLUSIVE PROPERTY OF REFLEX INC., AND IS DISCLOSED WITH THE UNDERSTANDING THAT IT WILL BE RETAINED IN STRICT CONFIDENCE, THAT IT WILL NOT BE DUPLICATED IN WHOLE OR IN PART, AND THAT IT WILL NOT BE USED FOR ANY OTHER PURPOSE THAN THAT FOR WHICH IT IS DISCLOSED.

PCB. NO. 13501 -00125  
 LAYOUT NO. 12M03-00125

DR	MY	CKTD	APP'D	G	GEMIN CONTROLS CEDARBURG, WI
DATE	SCALE	SHEET	OF		
8-24-82					
PRODUCT				REF. FILE NO. J	
VOLTAGE /CURRENT FOLLOWER				EX-235	
CUSTOMER				JOB NO.	
TITLE				DWG. NO. 12M03-00125-01	
				SCHEMATIC DIA.	